

INSULATED HOT CABINET WITH HUMIDITY MODEL H-135-WUA-11

FEATURES AND BENEFITS:

- Fully insulated holding cabinet keeps prepared foods at serving temperatures.
- Powerful, yet efficient, 2000 Watt heating system maintains the right combination of heat and humidity to properly hold products.
- Humidity system allows you to regulate humidity levels by controlling air temperatures to 200°F (93°C). Lowering air temperatures allows for humidity up to 95%
- Integral drip trough on front keeps traffic area dry, safer.
- Internal frame in body maintains structural rigidity.
- Body constructed of non-corrosive, Hi-Tensile aluminum for strength and ease of mobility.
- Insulated Dutch doors prevent temperature loss; door gaskets for proper seal. Field reversible for flexibility.
- Standard with right hand hinging; left hand hinging available upon request.
- Recessed push/pull handles on both sides prevent damage to walls; allows easy maneuvering.
- Safety-conscious anti-microbial door frames and latches reduce the spread of germs.
- Eleven sets of wire universal angles accommodate a large variety of pan sizes, adjustable 1-1/2" centers.
- Slanted control panel has easy-to-read thermometer; digital thermometer available upon request. Entire assembly removable for cleaning and maintenance.
- Heavy duty 5" swivel casters, two with brakes. Provides mobility when fully loaded.



H-135-WUA-11

SANITATION
NSF/ANSI 4

C US



ACCESSORIES and OPTIONS (Available at extra cost):

- Full View Window Door
- Red Vinyl Doors
- Extra Universal Angles
- Corner Bumpers
- Perimeter Bumper
- Push Handle
- Floor Lock (for use with 5" casters)
- Various Caster Options
- 208 or 240 Volt Service
- Food Safe Digital Thermometer

See page B-20 for accessory details.

H-135-WUA-11

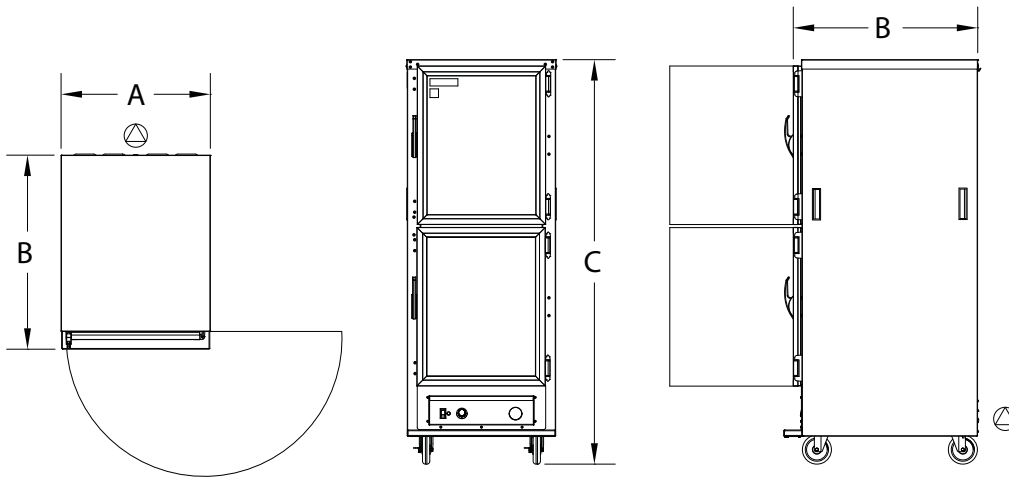

CRES COR MODEL NO.	PAN			DIM "A"	DIM "B"	DIM "C"	INSIDE DIMENSIONS				WEIGHT ACT.
	CAP/ANGLES	SIZE		WIDTH	DEPTH	HEIGHT	WIDTH	DEPTH	HEIGHT		
H-135-WUA-11	11 SETS	SEE NOTE BELOW	IN	25-3/4	33-1/2	69-3/4	21-3/4	27	54	LBS	225
			MM	655	850	1775	555	690	1375	KG	102

NOTES: 1. Pan sizes 22" x 20" (560 x 510) Roast & Bake Pans, 10" x 20" (255 x 510) Roast & Bake Pans, 18" x 26" (460 x 660) Bun Pans, 14" x 18" (355 x 460) Service Trays, 12" x 20" (305 x 510) Steam Table Pans.
Refer to Pan Size Chart at end of section.

2. When ordering bumpers, add 2" to overall dimensions.

ALL CONSTRUCTION IS RIVETED, WELDED AND FINISHED.

CABINET:

- Body: .063 aluminum.
- Reinforcement: Internal framework of .100 aluminum.
- Insulation: Fiberglass, thermal conductivity (K factor) is .23 at 75°F, 1" insulation in sidewalls, 1-1/2" in top and back.
- Air tunnel: .063 aluminum; lift-out type, mounted on back panel.
- Push/pull handles (2): Black plastic; 5-1/2" vertical; recessed.

BASE:

- Full base construction, .125 aluminum.
- Casters: 5" dia., swivel, modulus tires, 1-1/4 wide, load cap. 250 lbs. each, temp. range -40°/+180°F. Delrin bearings. Front casters equipped with brakes.

DUTCH DOORS:

- Field reversible.
- Frame: Anti-microbial, black powder coated extruded aluminum, fastened together.
- Gaskets: Perimeter type, santoprene rubber.
- Panels: 3/16 Aluminum vinyl cover, anti-microbial, insulated panels, fitted into door frame.
- Latches: Magnetic type with anti-microbial pull handle.
- Hinges (4): Chrome plated high-pressure cast zinc.

PAN SLIDES:

- Wire angles (.306 dia.) nickel chrome plated steel, mounted on lift off posts.
- Spaced on 4-1/2" centers; adjustable on 1-1/2" centers.

HOT UNIT COMPONENTS:

- Removable bottom mount hot unit.
- Body: Formed .063 aluminum with black control panel.
- Thermostat (holding): Electro-mechanical, room ambient to 200°F (93°C).
- Thermostat (humidity): Electro-mechanical, room ambient to 95%.
- Pilot light.
- Switch: ON-OFF rocker type.
- Power cord: Permanent, 6 ft., 14/3 ga. with molded right angle plug.
- Heaters (2): 960 Watts for holding.
- Blower motor.
- Thermometer.
- Water pan: 3-1/2 quart; 22 ga. 304 stainless steel with 960 Watt heater for humidity.

POWER REQUIREMENTS:

- 2000 Watts, 120 Volts, 60 Hz., single phase, 16 Amps., 20 Amp. service.

SHORT FORM SPECIFICATIONS

Cres Cor Insulated Holding Cabinet Model H-135-WUA-11. Inner, outer and top liners of .063 aluminum. (11) sets wire angles for multiple pan sizes, adjustable spacing every 1-1/2". Field reversible Dutch doors, 3/16 insulated vinyl covered aluminum panels. Insulated with 1-1/2" fiberglass in top and back, 1" in sidewalls. Removable 2000 Watt, 120 Volt power unit. Full base, .125 aluminum. 5" swivel modulus casters, Delrin bearings. Load capacity 250 lbs. each. Provide the following accessories: _____. CSA-US, CSA-C, CSA to NSF4 listed, ENERGY STAR Qualified.



5925 Heisley Road • Mentor, OH 44060-1833
Phone: 877/CRESCOR • Fax: 440/350-7267
www.crescor.com

© Crescent Metal Products, Inc. 2010 All rights reserved.

In line with its policy to continually improve its products, CRES COR reserves the right to change materials and specifications without notice.

Litho in U.S.A.